

This document is the property of Amphenol Corporation and is delivered on the express condition that it is not to be disclosed, reproduced or used, in whole or in part, for manufacture or sale by anyone other than Amphenol Corporation without its prior consent, & that no right is granted to disclose or to use any information in this document.

Customer Drawing

REVISIONS				
SYM	ECN	DESCRIPTION	DATE	APPROVED
4	HK5847	RELEASE TO MASS PRODUCTION	8/11/09	IP

NOTES:

1. Material HOUSING: THERMOPLASTIC, UL94V-0
 COLOR: BLACK
 CONTACT: PHOSPHOR BRONZE
 PLATING: UNDER PLATING WITH NICKEL 1.27u MIN.
 OVER PLATING WITH GOLD ON MATING AREA
 GOLD PLATING THICKNESS REFER TO P/N SYSTEM
 PURE TIN 2.54u MIN. PLATING ON TERMINAL
 SOLDER TAB: BRASS.
2. ELECTRICAL SPECIFICATION: MAXIMUM RATED CURRENT: 1.5Amps@30°C MAX.
 CONTACT RESISTANCE: 30 MILLI-OHMS MAX.
 INSULATOR RESISTANCE: 1000MEGOHMA MIN.
 DIELECTRIC WITHSTANDING VOLTAGE: 500 V AC
3. MATERIAL SHOULD BE FULFILLED AMPHENOL SPEC# SSN002.
4. PREMATING AT P4 & P12
5. ORDER P/N SYSTEM: SAS-F313-004-X-XX

MATING AREA PLATING
 1-Au 0.76um MIN.
 2-Au 0.38um MIN.
 3-Au GOLD FLASH

PACKING
 NIL-TRAY WITHOUT PICK-UP CAP
 C-TRAY WITH PICK-UP CAP
 TR-TAPE AND REEL
 WITH PICK-UP CAP

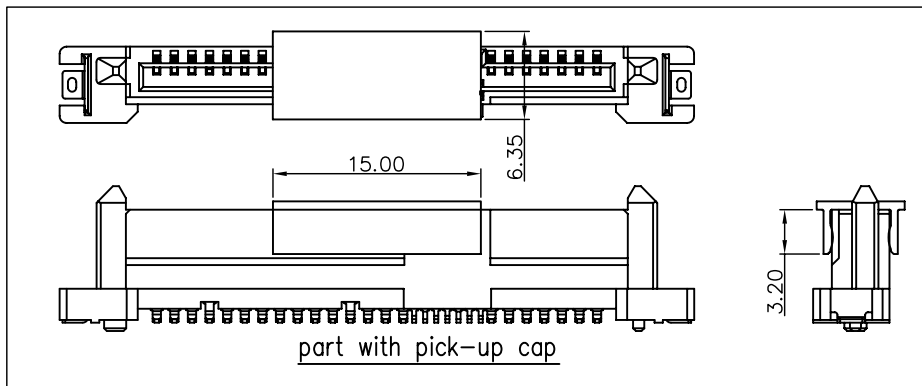
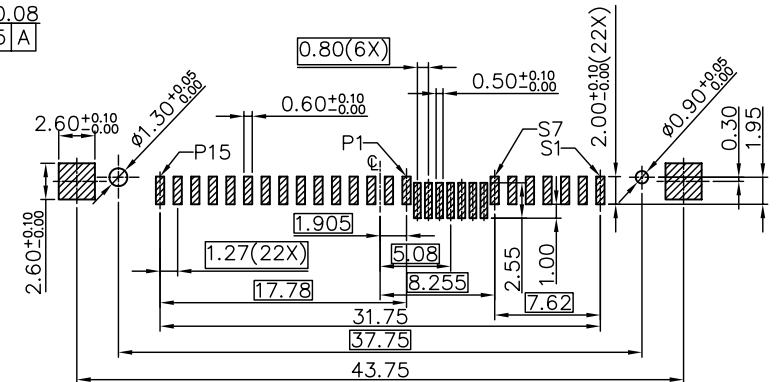
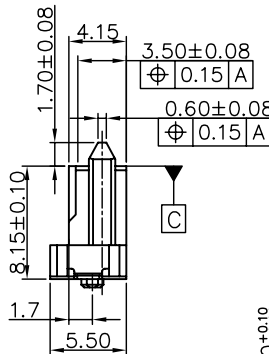
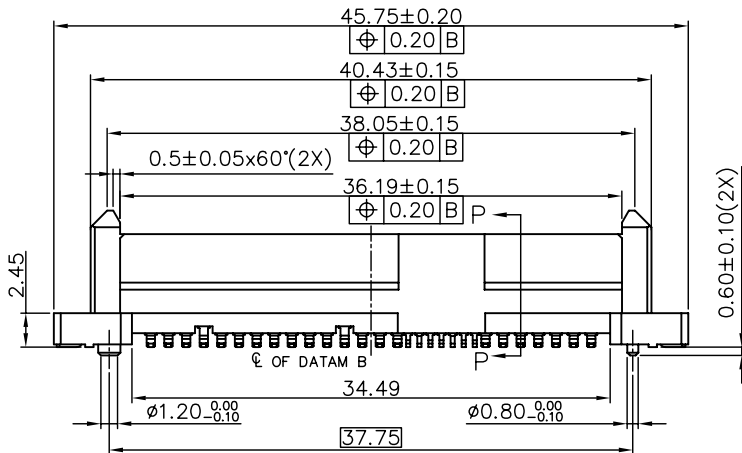
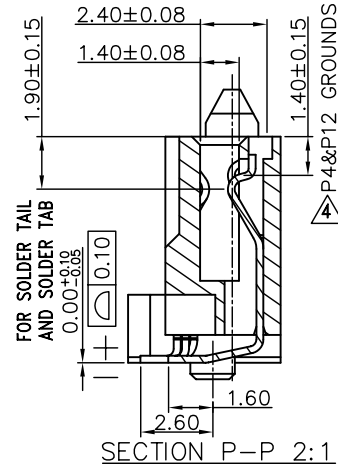
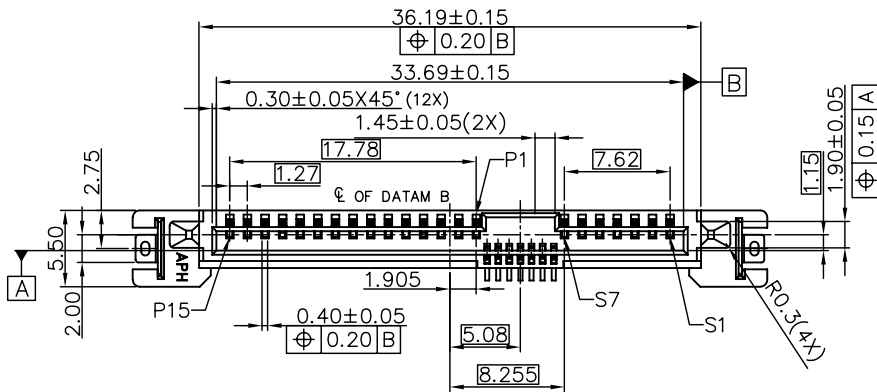

UNLESS OTHERWISE SPECIFIED TOLERANCES		APPROVAL		DATE	Amphenol
U.S.	METRIC	DRAWN	DATE		
X	+/-	Wilson.Lu	8/11/09		TITLE CUSTOMER DRAWING FOR 6G SAS STRAIGHT SMT RECEPTACLE
.XX	+/-	Tom.Tang	8/11/09		
FRACTIONS	+/-	CHECKED			SIZE A3
ANGLES	+/-				
FOR MATERIALS AND FINISHES SEE NOTES		DRAWING FILE:			REV. 4
REMOVE SHARP EDGES		ANGLE OF PROJECTION			
DIMENSIONS		U.S.			SCALE NONE
		INCHES			
(METRIC)		(MM)			SHEET 1 OF 1